

**LOGOSOL**

# USER MANUAL

Ref. no. 0458-395-2345

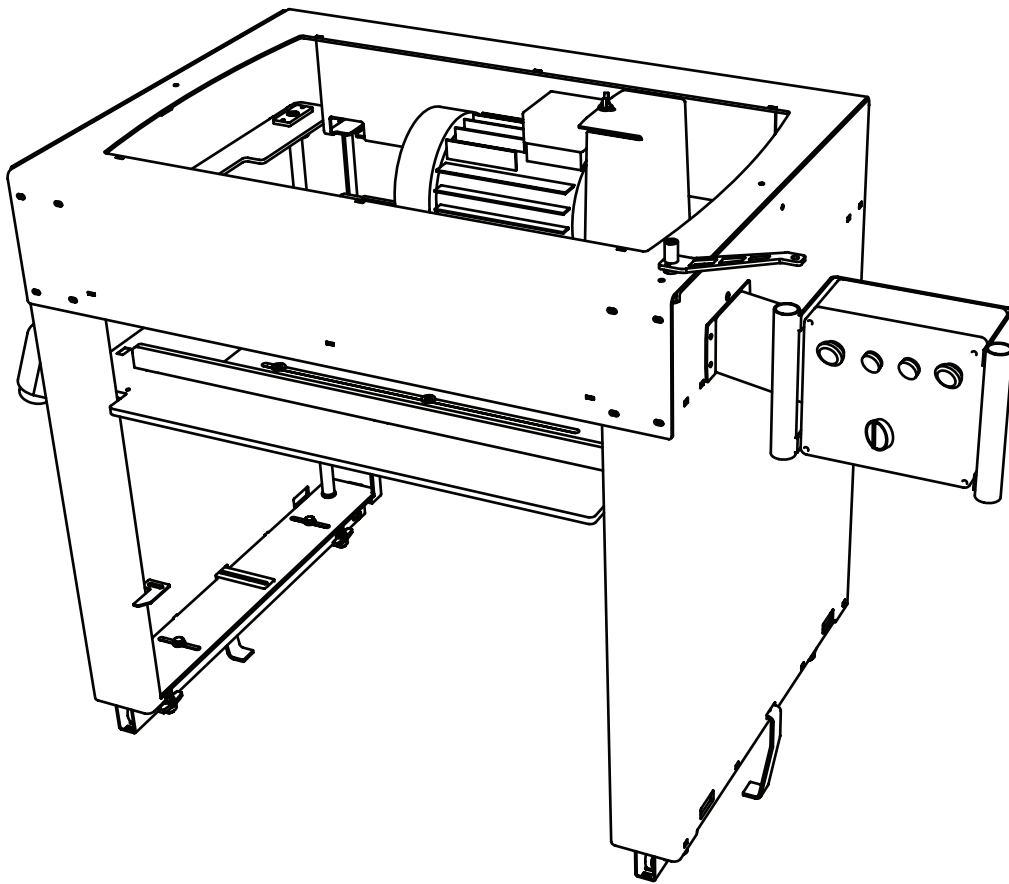

## **LOGOSOL LM410**

LOG HOUSE MOULDER

**EN**

## THANK YOU FOR CHOOSING A LOGOSOL MACHINE!

**W**e are very pleased that you have demonstrated your confidence in us by purchasing this machine, and we will do our utmost to meet your expectations.

Logosol has been manufacturing equipment since 1989. In that time we have supplied approximately 50,000 machines to satisfied customers the world over.

We care about your safety as well as we want you to achieve the best possible results with this product. We therefore recommend that you take the time to carefully read this user manual from cover to cover in peace and quiet before you begin using the saw. Remember that the machine itself is just part of the value of the product. Much of the value is also to be found in the expertise we pass on to you in the user manuals. It would be a pity if that were not utilised.

We hope you get a lot of satisfaction from the use of your new machine.

*Bengt-Olov Byström*

**Bengt-Olov Byström**

Founder and chairman,  
Logosol in Härnösand, Sweden



Read through the user manual carefully and make sure you understand its contents before you use the machine.



This user manual contains important safety instructions.



**WARNING!** Incorrect use can result in serious or fatal injuries to the operator or others.



LOGOSOL continuously develops its products. For this reason, we must reserve the right to modify the configuration and design of our products.  
Document: LOGOSOL LM410 User Manual  
Ref. No. User Manual, English: 0458-395-2345  
Text: Mattias Byström, Martin Söderberg, Robert Berglund  
Illustrations: Mattias Byström, Martin Söderberg, Robert Berglund  
Last revised: November 2018  
© 2018 LOGOSOL, Härnösand Sweden

**#1**

## TABLE OF CONTENTS

Safety instructions	4
Description of the machine	6
Technical data	7
List of components	8
<b>Assembly: wheel suspension &amp; anti-tip guards</b>	<b>14</b>
<b>Assembly: control panel</b>	<b>15</b>
<b>Installing moulding knives</b>	<b>16</b>
<b>Installing planing knives</b>	<b>17</b>
Installing the log moulder on the rails	18
Operation	19
Belt tension/belt replacement	20
Moulding log house timber	22
Chip management	24
Maintenance	25
Troubleshooting	26
Electrical system	28
Declaration of Conformity	29

## SAFETY INSTRUCTIONS

- Read carefully through the entire user manual before starting to operate the machine. Failure to observe these safety instructions may result in fatal injuries.
- Make sure that everyone who uses the machine is well informed of the dangers and has read the user manual. The user manual shall always be available to the persons working with the machine. This also applies where the machine is sold or loaned out.
- Minors under 18 years of age are not allowed to operate the machine.
- Make sure that children and animals are not in the vicinity when the machine is being operated.
- Respect the safety distances to avoid injury from high noise levels.
- Anyone working with the machine must be fit for work, healthy and in good physical condition. Make sure you take regular breaks when operating the machine. Never operate the machine while under the influence of alcohol, narcotics or other drugs or medicines that can cause drowsiness or inattention.
- The machine is only to be operated where visibility is good. It is not to be operated in the dark or where visibility is poor.
- Never work alone and make sure there are other persons within earshot who you can summon if you need help.
- Always wear protective clothing and use personal protective equipment: Close-fitting work overalls are appropriate. Never operate the sawmill wearing loose-fitting clothes, overall coats or similar.
- Use safety shoes with high-grip soles and steel toecaps. Neckerchiefs, ties, jewellery or other items that can get caught in the equipment are not to be worn.
- Wear strong protective gloves. Risk of cut injuries when handling cutting equipment. The cutting equipment can also be hot immediately after sawing.

### Key to symbols



For your own safety, read through the entire user manual carefully and do not start the machine before you have understood everything.



Use approved ear protectors and protective eyewear. Hearing can be damaged even after short periods of exposure.



Sharp rotating tools. Make sure that your fingers never come near the cutting tools.



This symbol means 'WARNING'. Pay particular attention where this symbol appears in the manual text.



This symbol is followed by instructions that must be observed. Pay particular attention where this symbol appears in the manual text.

### Safety distances



Respect the safety distances. The safety distance is 5 m for the operator and 15 m for persons other than the operator. The illustration below shows the machine from above. The operator is to remain within the area marked with a dashed line (- - -) when the machine is in operation.

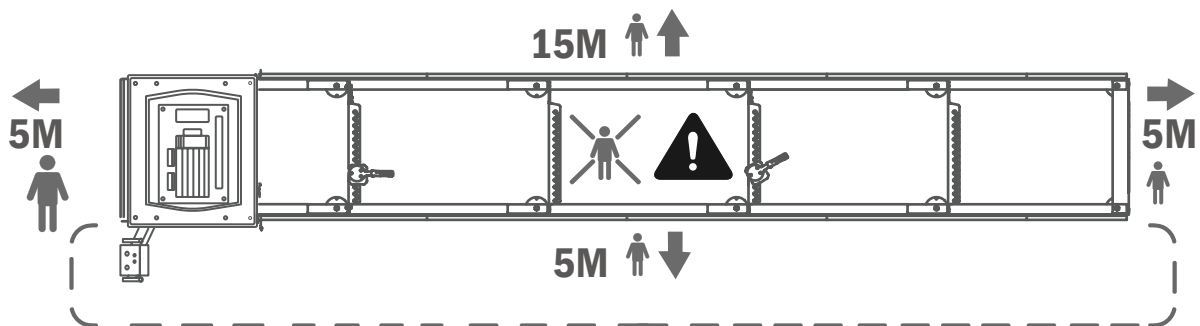

## MACHINE DESCRIPTION

The LM410 is a log moulder that is designed to be pushed manually on rails. The wheels, which are guided by two or three sides of the rails, are suspended by separate wheel suspensions, which can individually be adjusted laterally.

In its standard configuration, the Log House Moulder fits on rail frames that are from 850 to 1050 mm (33 1/2" to 41 7/16") wide.

The workpiece, which should be of large dimensions, must be securely fixed between the rails.

The machine consists of a sturdy chassis of 4 mm (3/16") steel sheet, with a height-adjustable table of 10 mm (7/16") steel sheet.

On the table there is a cutter, which can be adjusted laterally. The cutter head is 410 mm (16 3/16") wide and 72 mm (2 7/8") in diameter. For the cutter head, there is a wide range of standard moulding knives available.

The electric LM410 model is started by a main switch and a two-hand "hold-to-run" control.

## TECHNICAL DATA

The LM410 fits directly on band sawmills with a rail frame width from 825 to 960 mm. It can be installed on both narrow, flat and angled rail types. The flexible wheel suspension can be guided from the inner or the outer side, or from both sides of the rails. If the rail frame width does not correspond, customized adaptor plates can be made to order. The same applies if the two rails are of different heights.

### Dimensions and weight

Length: 720 mm  
Height: 1000 mm  
Width: 1400 mm  
Weight: approx. 200 kg

### Timber dimensions

Max. width: 600 mm  
Height from rails: 600 mm

### Cutter

Diameter: 72 mm  
Width: 410 mm  
Rotational speed: approx. 6000 rpm  
Max. take-off when planing: 7 mm  
Max. profile depth: 25 mm  
Lateral adjustment: 200 mm  
Planing knives are included as standard. Same cutter type as for the PH260.

### Motor options

400V 3-phase. Power: 4 kW.  
220V 3-phase. Power: 4 kW (for Norway).  
270cc petrol engine.

### Recommended accessories

Chip chute 100 mm  
Chip hose  
Hundreds of different standard moulding knives (see our tool catalogue), including up to 200 mm wide traditional Scandinavian log house timber profile. Custom-made moulding knives can be ordered.

# COMPONENTS

## LIST OF COMPONENTS A

Pos.	Description	Quantity	Ref. no.
1	Electrical box	1	9999-000-9999
2	Hoisting ring	0	9999-000-9999
3	Anti-tip guards LM	2	9999-000-9999
4	Industrial inlet	1	9999-000-9999
5	Crank	1	9999-000-9999
6	Horizontal chassis	1	9999-000-9999
7	Vertical chassis L	1	9999-000-9999
8	Vertical chassis R	1	9999-000-9999
9	Wheel suspension (E)	2	9999-000-9999
10	Trapezoidal threaded bar	3	9999-000-9999
11	Chain tensioner	2	9999-000-9999
12	Table (C)	1	9999-000-9999
13	Trapezoidal bar, crank	1	9999-000-9999
14	Cutter head (B)	1	9999-000-9999
15	Mounting bracket	2	9999-000-9999
16	Handle	1	9999-000-9999



A

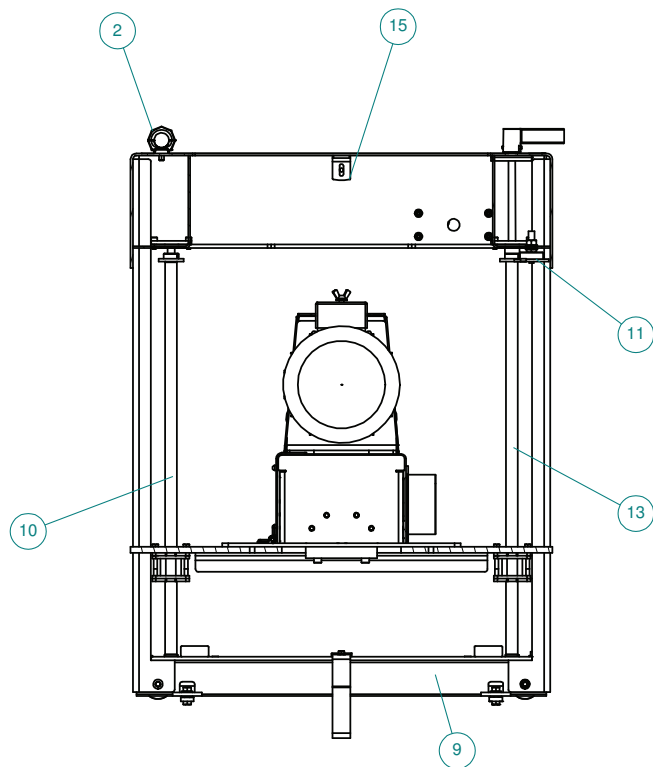
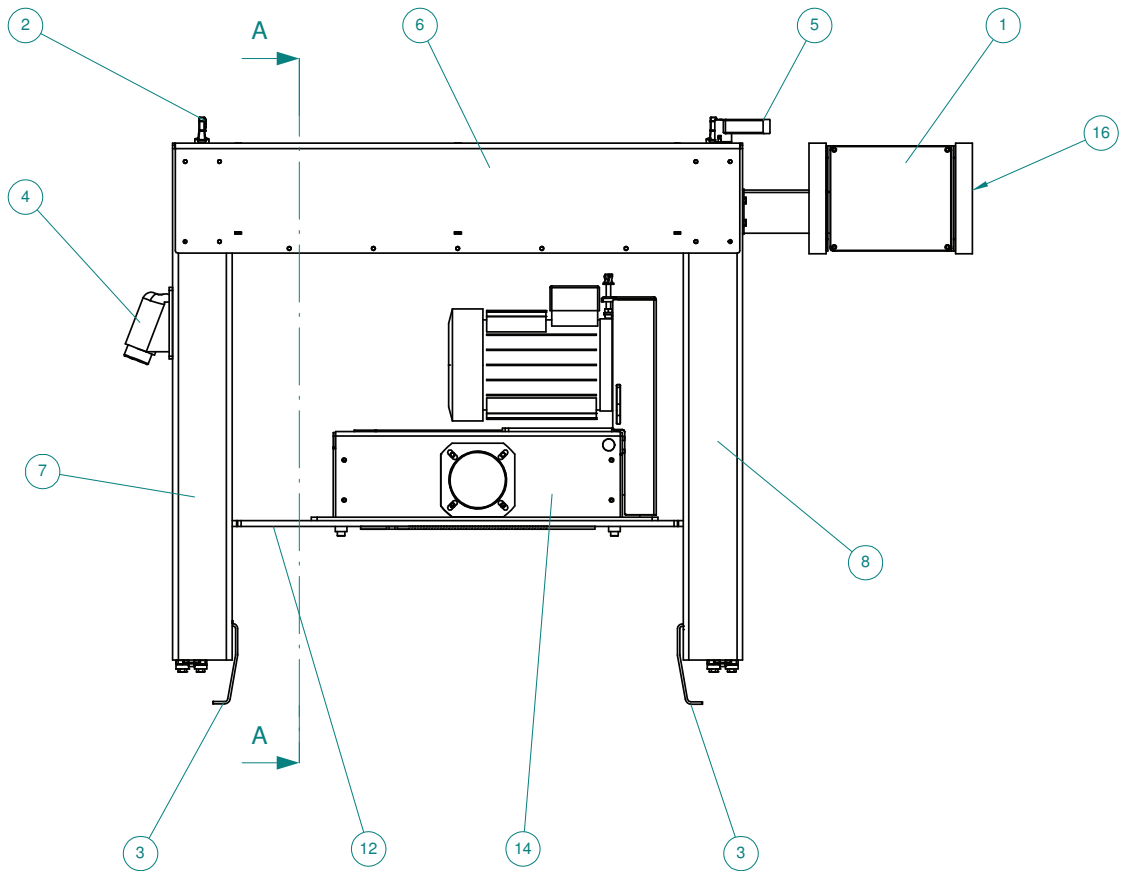

# COMPONENTS

## LIST OF COMPONENTS B

Pos	Description	Quantity	Ref. no.
1	Cutter head chassis	1	9999-000-9999
2	Bearing block	2	9999-000-9999
3	Cutter head	1	9999-000-9999
4	Ball bearing 30x62	2	9999-000-9999
5	Side plate, belt side	1	9999-000-9999
6	Electric motor B14	1	9999-000-9999
7	Chip deflector	1	9999-000-9999
8	Bottom plate, cutter head	1	9999-000-9999
9	Side plate L	1	9999-000-9999
10	Belt pulley 49 mm	1	9999-000-9999
11	Chip outlet cover	1	9999-000-9999
12	Hatch	1	9999-000-9999
13	Switch	1	9999-000-9999
14	Belt cover	1	9999-000-9999
15	Motor mount	1	9999-000-9999
16	Hinge	2	9999-000-9999
17	Chip chute KS150	Optional	9999-000-9999
18	Belt pulley 118 mm	1	9999-000-9999

B

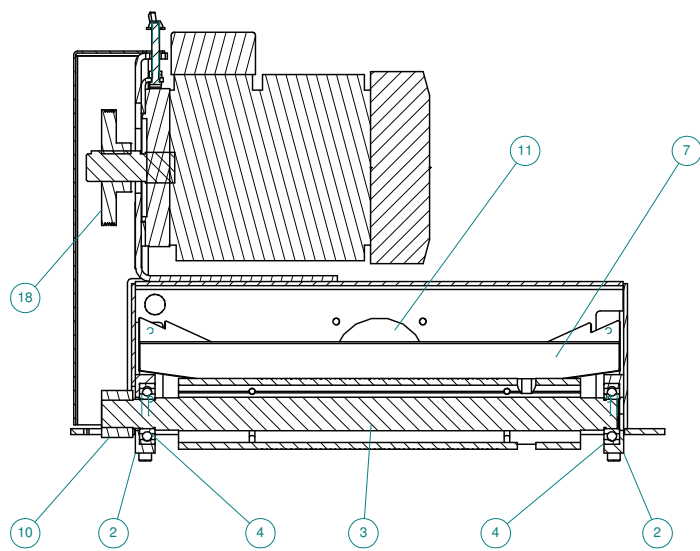
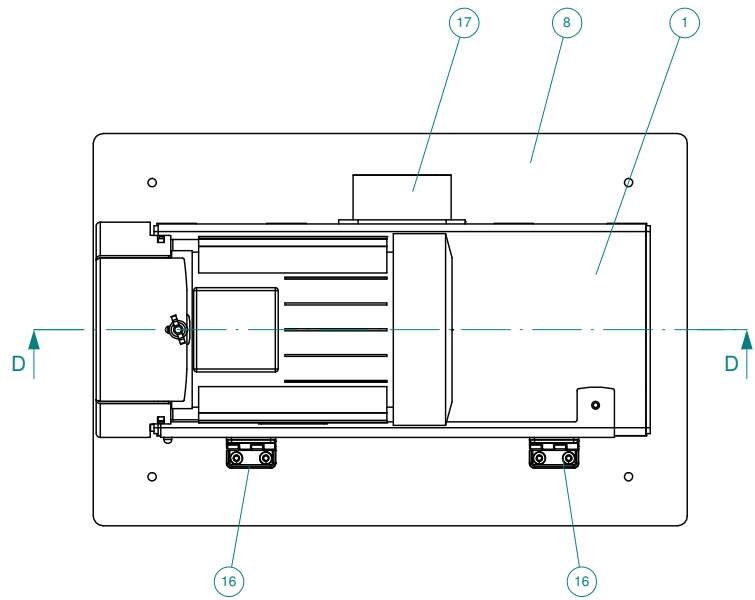
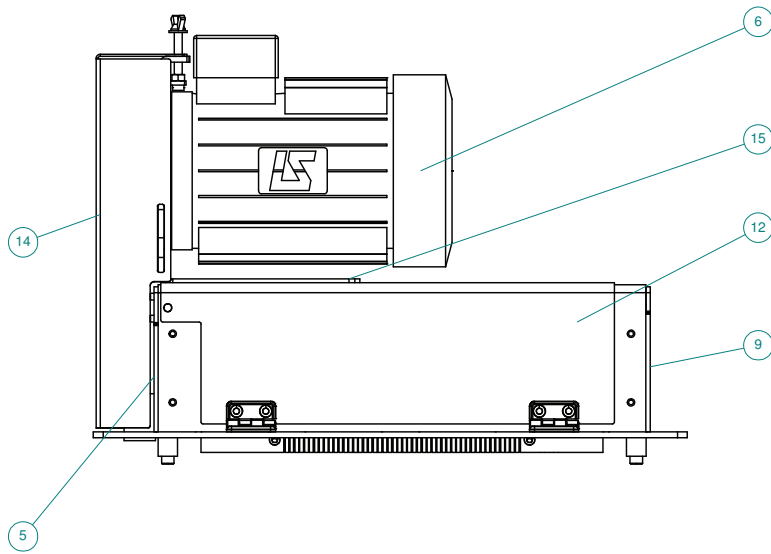

# COMPONENTS

## LIST OF COMPONENTS C

Pos.	Description	Quantity	Ref. no.
1	Adjusting nut compl. (D)	4	9999-000-9999
2	Table	1	9999-000-9999
3	Reinforcement bracket	2	9999-000-9999

## LIST OF COMPONENTS D (Adjusting nut)

Pos.	Description	Quantity	Ref. no.
1	Nut support	1	9999-000-9999
2	Trapezoidal nut	1	9999-000-9999
3	Nut lock	1	9999-000-9999
4	Rubber washer	1	9999-000-9999
5	Bolt M6x55	2	9999-000-9999

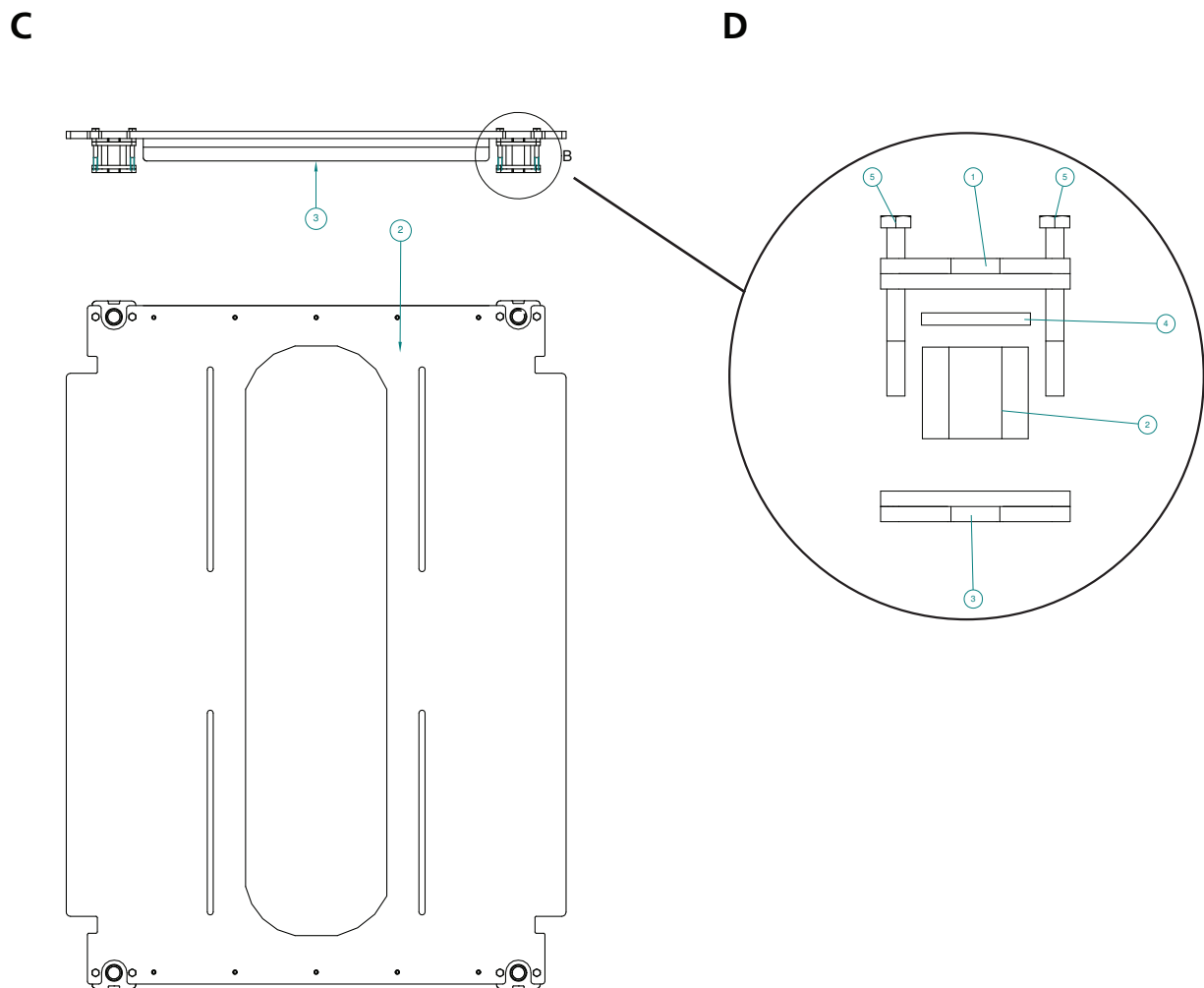

# COMPONENTS

## LIST OF COMPONENTS E (Wheel suspension)

Pos.	Description	Quantity	Ref. no.
1	Bogie	1	9999-000-9999
2	Wheel 10mm	2	9999-000-9999
3	Ball bearing 8x22x7	4	9999-000-9999
4	Bolt M8x25	4	9999-000-9999
5	Ball bearing 6201	2	9999-000-9999
6	Spacer	4	9999-000-9999
7	Bolt M8x40	2	9999-000-9999
8	Washer M8	12	9999-000-9999
9	Nut M8	8	9999-000-9999

E

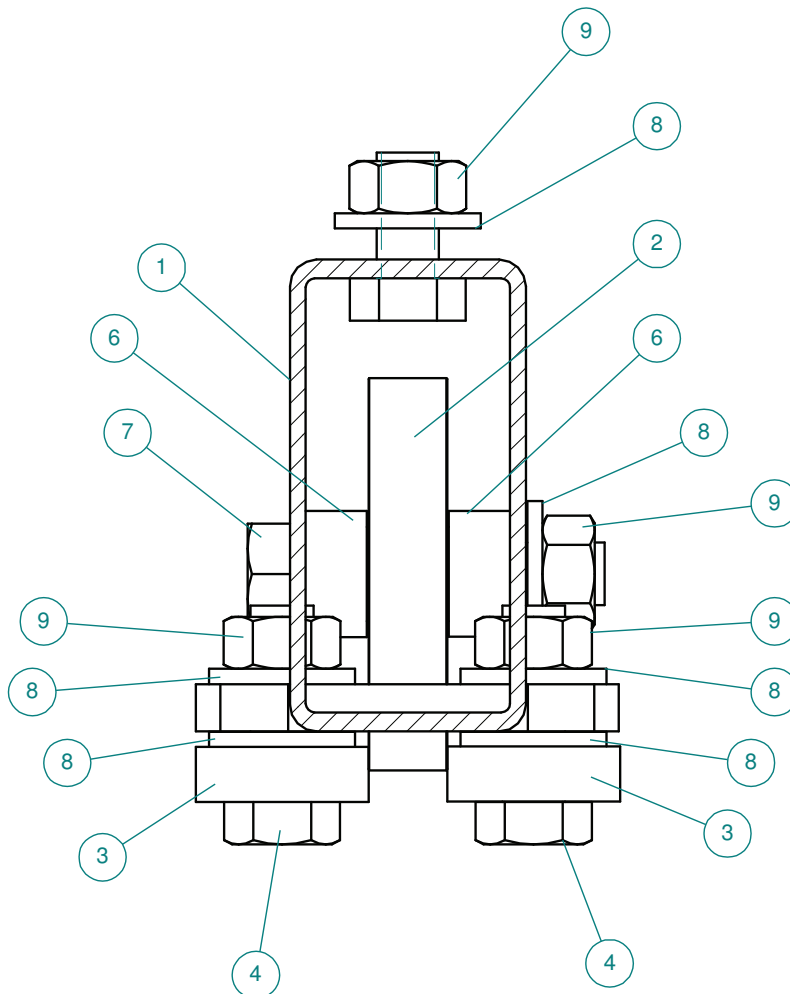

## ASSEMBLY: WHEEL SUSPENSION & ANTI-TIP GAURDS

Place four wooden blocks (approx. 20x20x20 cm) under the machine table. Lift the log house moulder by lowering the table against the blocks until you can reach and adjust the wheel suspension on the underside of the machine.

Do not raise the machine to a higher position than necessary,

Measure the distance between the centres of the rails. Adjust the wheel suspensions so that you have the same distance between the wheels on the opposite sides as between the rails.

⚠️ Crushing risk.

🔧 Make sure that the machine stands firmly before you start adjusting the wheels.

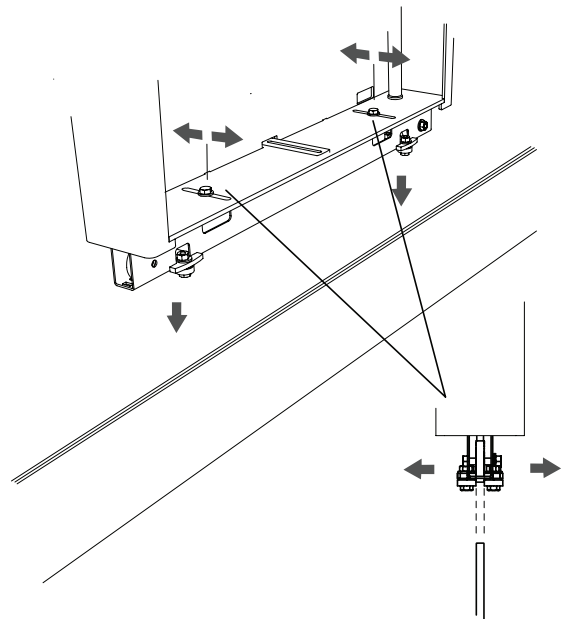

### Install the anti-tip guards

Fit the anti-tip guards to the outsides of the machine. The anti-tip guards are laterally adjustable.

Adjustments of the anti-tip guards are made on the inner side of the machine chassis.

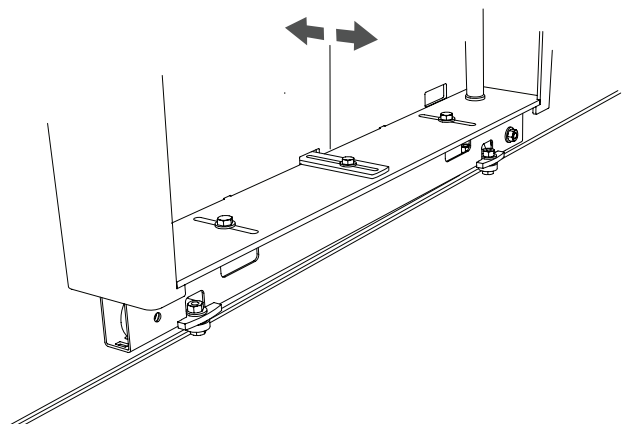
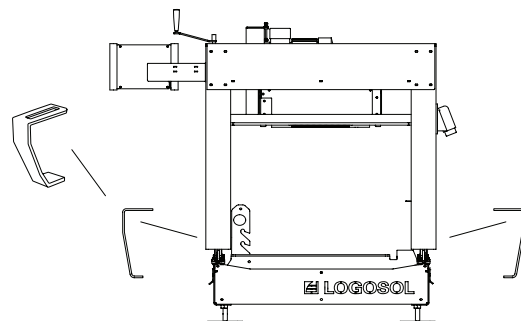

## ASSEMBLY: CONTROL PANEL

The control panel is not installed when the machine is shipped, but lies on the machine table inside the machine.

Fit the control panel to one of the shortsides of the machine. In the box of components, which also lies on the machine table, you find the two bolts that are to be used for fitting the control panel to the machine.



- A: Hold-to-run control, start
- B: Hold-to-run control, start
- C: Main switch
- D: Indicator lamp for the main switch
- E: Indicator lamp for the cutter motor

## INSTALLING MOULDING KNIVES

⚠ Before opening the hatch of the log house moulder, ensure that the power is disconnected and that the cutter head is not rotating. Use protective gloves. This is especially important when you are loosening difficult bolts, or when you are tightening bolts. Be careful with the planing knives. You can easily get cut by them, even when just touching them lightly.

The moulding knives should always be mounted in pairs and in the same lateral position in the opposite slots of the cutter head. A certain degree of lateral deviation between the moulding knives can, however, be accepted, as long as the cutter head stays balanced.

### Installation

- Assemble together the knife gib (chip breaker) and the moulding knife.
- Insert the gib and the moulding knife in the wide end of the slot in the cutter head.
- Push the knife and the gib along the slot, and then secure them by turning the bolt on the back of the gib anticlockwise until it presses against the side of the slot.

⚠ Lack of balance in the cutter head creates vibrations that can damage the machine and cause serious injury.

⚠ The moulding knives must always be installed in pairs so that the cutter head stays balanced. You must always mount identical knives in the opposite slots of the cutter head.

⚠ Risk of serious injury if the knives and knife gibs come loose or break.

⚠ Knives, knife gibs and cutter head must be perfectly clean before they are mounted. Immediately replace damaged knives and knife gibs.

⚠ The lock screw of the knife gib must be fixed in the narrow part of the slot. It should not be fixed in the wide end of the slot. Neither should the knife gib protrude outside the cutter head. If a knife gib is in an incorrect position, move the whole cutter head and restart installing the knives.

### After installation of moulding knives

⚠ Make sure that there are no tools left inside or

on the machine, or on the workpiece that is to be machined.

⚠ Make sure that all bolts are securely tightened.

⚠ Make sure that the cutter head can rotate freely before closing the hatch.

### Fragile knife profiles

The longer and thinner protrusion of the knife, the more careful you have to be when using it. It is not certain that all knife profiles can stand the same feeding speed. Be extra careful when machining hardwood or wood with a lot of knots. Use common sense, but as a rule of thumb the knife is very fragile if the depth of the cut is twice as much as the width of it (e.g. a 10 mm wide groove that is 20 mm deep). In this case you have to handle the knife with care so that it does not break. A depth of cut that is of the same measurement as the width should be handled with a certain degree of care, and knives with a cutting depth that is less than half of the width it cuts (e.g. a 10 mm wide groove that is 5 mm deep) can stand rather hard treatment.

Sharpen the knife before it becomes dull.

NB: If the knives are dull, the risk that they break increases, and consequently also the risk of personal injury!

If you sharpen the knife before it becomes dull, it will be easier to resharpen it. If you are using a dull knife, the edge can be damaged, among other things by the heat. If you notice that the knife is dull (one indication is that the quality of the cut degrades) you must stop the machine immediately.

### Pressure marks

Sometimes, light spots can appear on the machined surface. These are pressure marks caused by wood debris around the edge of the knife. The wood debris has been pressed between the machined timber and the back of the edge. In most cases, this is due to the knives beginning to lose their sharpness, but it can also be due to what type of wood you are machining or to insufficient capacity of the chip extractor.



## INSTALLING PLANING KNIVES

⚠ Before opening the hatch of the log house moulder, ensure that the power is disconnected and that the cutter head is not rotating. Use protective gloves. This is especially important when you are loosening bolts that are firmly tightened, or when you are tightening the bolts. Be careful of the planing knives. You can easily get cut by those, even when touching them lightly.

Two planing knives can be mounted in two opposite slots in the cutter head (planing knife 410 mm HSS, ref. no. 7000-002-8410). Moulding knives can at the same time be mounted in the two other slots.

⚠ Risk of serious injury if the knives and the knife gibs come loose or break.

⚠ Knives, knife gibs and cutter head must be perfectly clean before they are mounted.

### Installation

- Screw down the lock bolts (B) of the knife gib (A) until they reach the bottom.
- Insert the knife gib in the cutter head.
- Screw the adjusting bolts (C) into the cutter head, and insert the planing knife so that the heads of the adjusting bolts come in the indentation on the back of the knife.

After this, the knife can be raised or lowered with the help of the two recessed adjusting bolts (C) next to the cutter head's knife slot. Use a 4 mm Allen key.

**To get the planing knives at the correct height, the adjusting block (ref. no. 7500-000-1020) should be used. The knives should just touch the block when it is passed over them.**

- Tighten the lock bolts, which secure the knives, anticlockwise. Tighten loosely at first. Start from the sides, and move to the next until you reach the middle, then retighten all bolts firmly.
- Carefully tighten the adjusting bolts until they touch the bottom of the indentations of the knives. If these bolts are tightened too firmly, the knife will crack.

### After installation of planing knives

- ⚠ Make sure that there are no tools left inside or on the machine, or on the workpiece that is to be machined.
- ⚠ Make sure that all bolts are securely tightened.
- ⚠ Make sure that the cutter head can rotate freely before closing the hatch.

**The planing knives are removed by loosening the lock bolts (B) of the the knife gib (A). Then you raise the knives by loosening the adjusting bolts (C) (see above).**

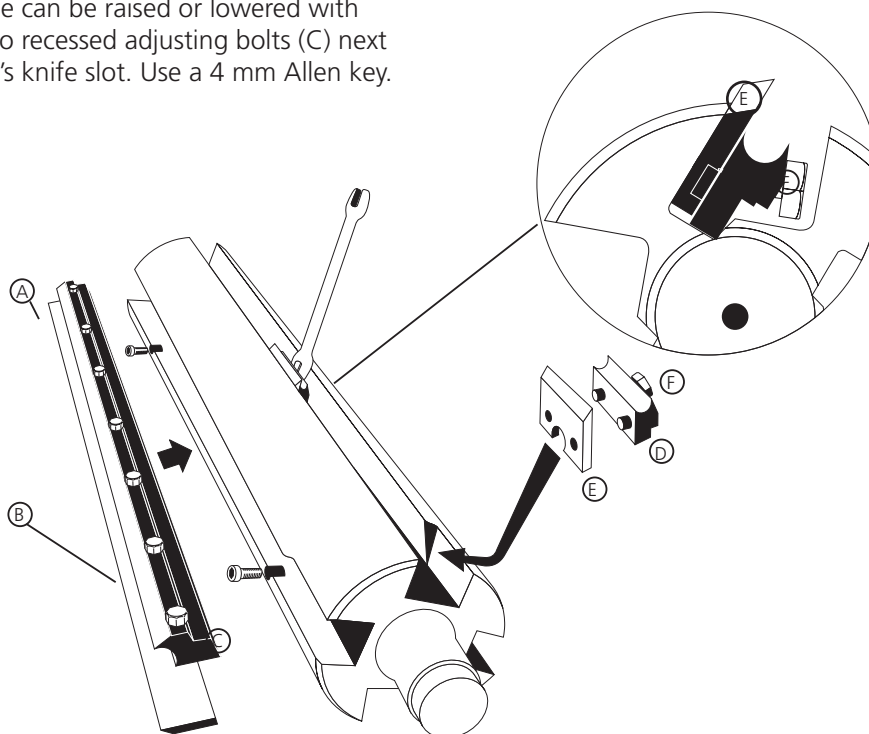

## INSTALLING THE LOG MOULDER ON THE RAILS

When the rails are adjusted and the wheel suspension is fitted, the log house moulder can be lifted onto the rails. Install the anti-tip gaurds. See page 14.

The log house moulder should be lifted by a truck, a tractor or the like. Lifting straps can be passed under the horizontal top chassis of the machine (A6) but the safest method is to use hoisting rings (not included) that you bolt to the top side of the machine. The machine weighs approx. 200 kg (441 lbs).

**⚠** Chrushing and tipping risk!

- ❶** Make sure the end stops on the rails are correctly fitted.
- ❷** A light wind can be enough to move the moulder on the rails. Secure the log moulder, with a strap e.g., when the machine is not being used.
- ❸** Ensure that the machine cannot accidentally tip off the rails. Consult Logosol if the anti-tip guards do not fit on your sawmill model.
- ❹** Make sure that all wheels and wheel bearings in the wheel suspension are correctly fitted on the rails and that all bolts are firmly tightened.
- ❺** Suspend the power cable from the ceiling or protect it in some other way. Never tread on the cable. The machine should be connected via a residual circuit breaker.
- ❻** Ensure the lighting is first-class.

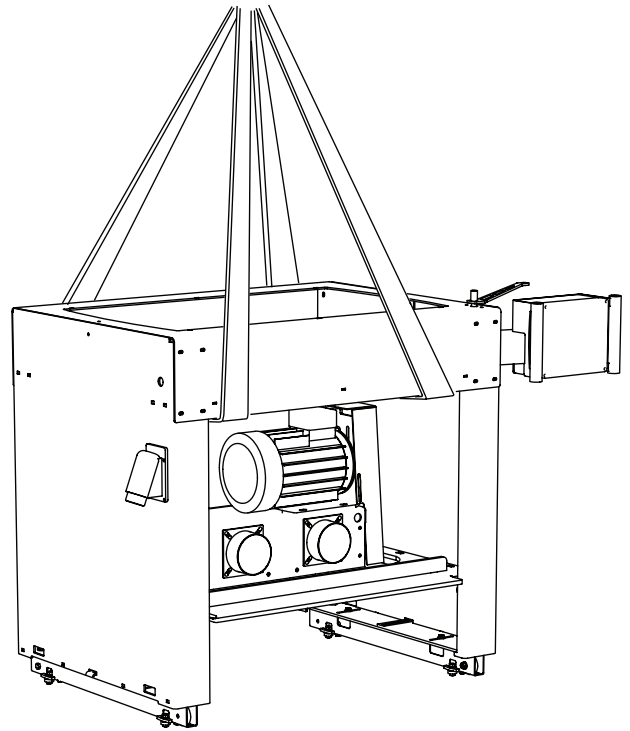

## OPERATION

### Starting the log house moulder:

Make sure that the hatch over the cutter head is completely closed. Perform the safety check under *Before starting the machine* in the Safety Instructions. Set the main switch to "ON". Take hold of the handles on the sides of the control panel, using both your hands, and press the both black buttons (hold-to-run controls) with your thumbs.

❗ When starting the machine, press the start buttons firmly and keep pressing them firmly during operation. Repeated activations or poorly pressed start buttons leads to sparking and wear on both the contactors and the start buttons.

When starting the machine, alternate between pressing the right button and the left button first. This way you even out the wear, but it is also a check that both the buttons work as they should.

### Emergency stop:

Release the start buttons.

### Stop:

Release the start buttons and set the main switch to "OFF".

❗ The cutter head can continue to rotate for up to 10 seconds after the start buttons have been released.

## BELT TENSION/BELT REPLACEMENT

⚠ If the belt jumps off the pulley or if it breaks, the cutter and the motor can continue to rotate several minutes. It can be difficult to see whether the motor and the belt are rotating.

⚠ Ensure that the power is disconnected before opening any protective covers or carrying out any servicing on the machine.

The cutter head is run by a double-pole, three-phase motor with 2800 rpm. The number of revolutions is geared up by a Poly-V belt transmission. The belt has to be tensioned or replaced after some time of use.

When the belt starts to squeak during operation, it should be tensioned or, if necessary, be replaced. If there are visible damages on the inside of the belt, it has to be replaced.

The belt is loosened and tightened as follows:

**1** Loosen the wing nut on the top of the belt guard and then remove the guard from the motor.

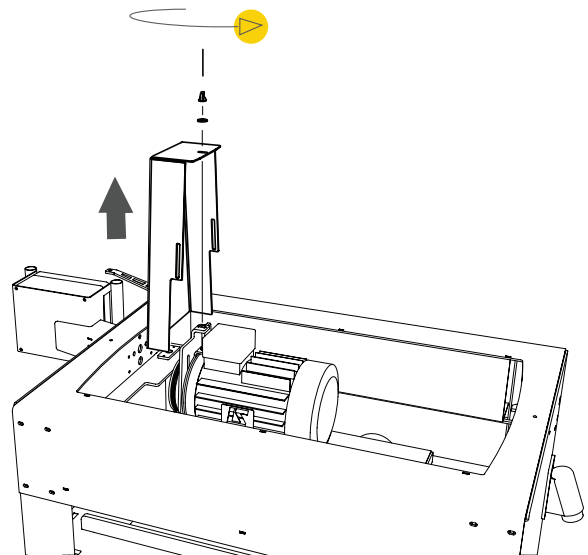

**2** Refit the wing nut and the washer. These are necessary for carrying out the adjustment.

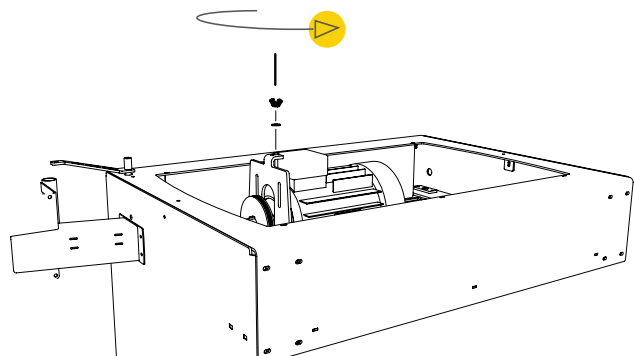

**3**

Loosen the four fixing bolts on the front of the motor. The bolts only have to be loosened enough to allow for adjusting the belt tension.

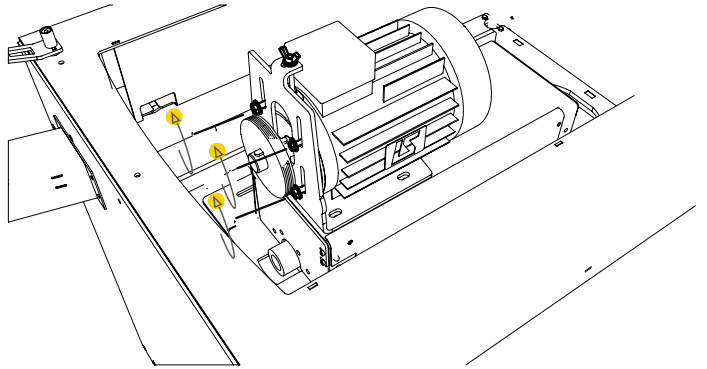

**4**

Adjust the belt tension by using the wing nut. The belt should be tightened until you by hand can rotate it 90 degrees.

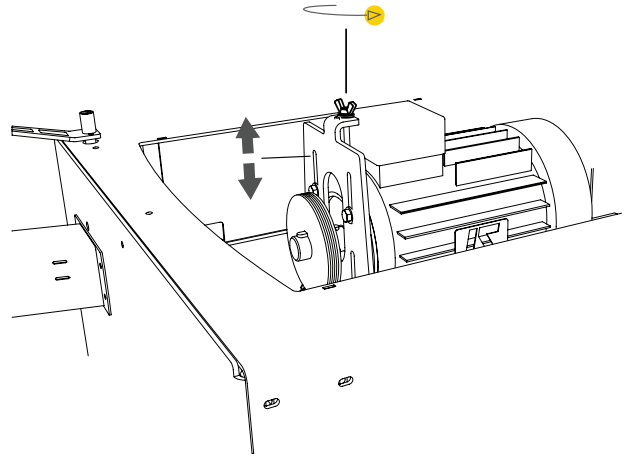

**5**

Refit the belt guard in the reverse order.

## MOULDING LOG HOUSE TIMBER

Below follows a description of how to mould 150 mm (approx. 6") wide log house timber on the sawmill B751. The method is the same for other widths and other profiles, even though the dimensions differ.

### Installing additional log supports

Three log supports should be used to ensure the best result. Fit the additional attachments (8210-001-0025, sold separately) in the inner attachment holes. With the eccentric attachment it is easy to set the log supports to a 90 degrees angle to the log bed.

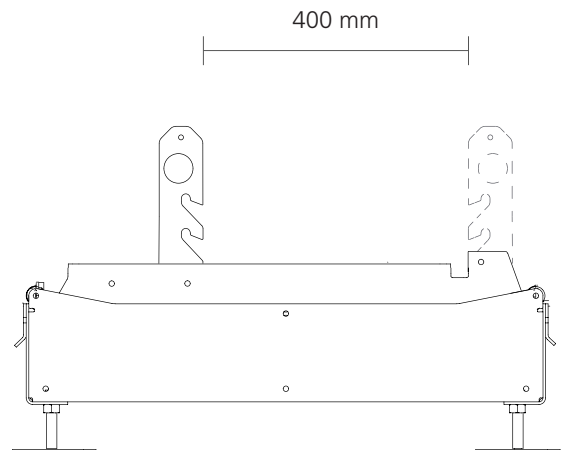

### Sawing a cant

Saw a cant to the width that you will use for the log wall, in this case 150 mm (approx. 6"). The cant can be conical or of uniform thickness.

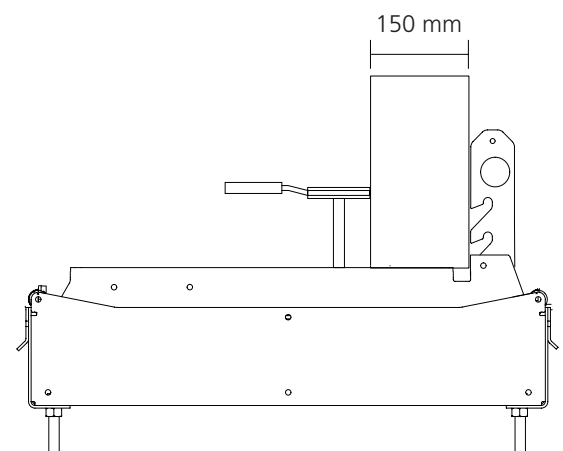

### Install the moulding knives in the cutter head

The cutter is 410 mm wide.

On one half of the cutter head you install the knives that only round the cant. On the other half you install the knives for rounding the edges and making the groove in the cant.

Fit the knives so that the centre of the knife profile will correspond with the centre of the sawn cant, in this case 75 mm from the log supports.

Mould the cant.

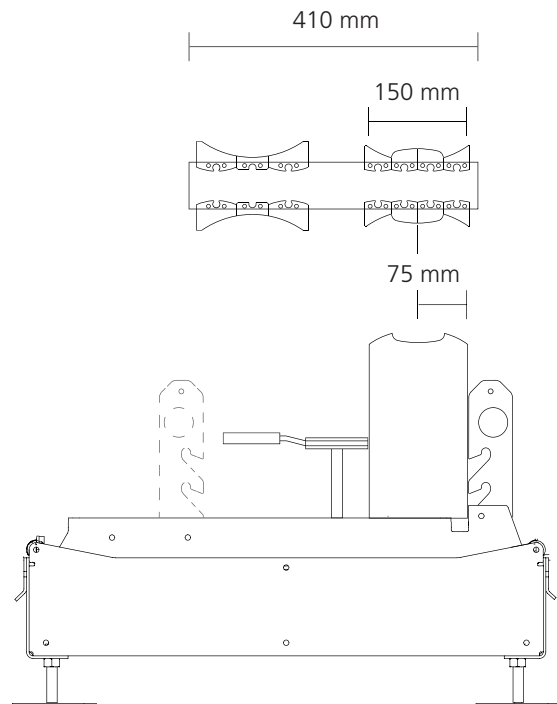

### Move the log supports and rotate the cant

Once one side of the cant is profiled, you move the log supports to the other side of the sawmill.

Rotate the log against the log supports and secure it.

Check and adjust the knives to make the centre of the knife profile correspond with the centre of the cant.

Mould the cant.

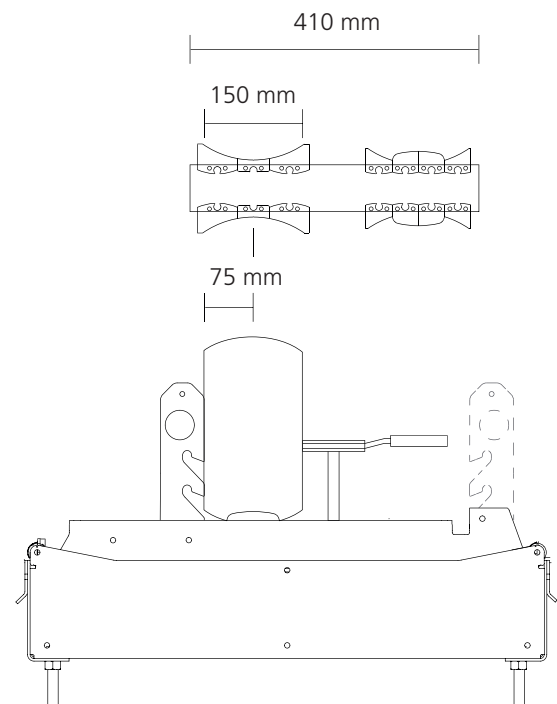

## CHIP MANAGEMENT

 Risk of serious injury.

 Never connect the machine if the chip outlet is open. Either the cover plate (B 11) or the chip chute (B 17) with hose secured with a hose clamp, must be fitted.

Maskinen kan användas utan spånfläkt även om det inte är att rekommendera då det blir mycket spån.

You should use an effective chip extractor with a capacity of at least 500 m<sup>3</sup>/h. 1.5 kW is sufficient in most cases.

Build a chip pocket, or blow the wood debris directly into a trailer or the like. Bear in mind that there has to be an air outlet in your chip container (e.g. a fine-meshed net, or a filter if you collect the wood debris indoors). Poor extraction capacity is often due to a too limited air flow out of the chip container. Build a chip pocket, or blow the wood debris directly into a trailer or the like. Bear in mind that there has to be an air outlet in your chip container (e.g. a fine-meshed net, or a filter if you collect the wood debris indoors). Poor extraction capacity is often due to a too limited air flow out of the chip container.

If you use the machine in a heated room, the chip extractor will soon cool the room if you do not direct the air back into the facility.

Dust emission and risk of fire have to be taken into consideration when collecting wood debris.

Connect the chip hose, and fasten it with hose clamps both on the log moulder and the chip extractor. Use the Flexi Hose from Logosol (length: 3 m (10 ft), ref. no. 7000-000-1015) which has a smooth inside improving the flow.

If you want to convey the wood debris a long way: Place the chip extractor close to the machine, so that you can use as short hose as possible. Then convey the wood debris in a sheet metal pipe, which reduces resistance for the air flow.

 Risk of fire and dust emission when collecting wood debris.

 Consult your local authorities about the regulations in your district.

 Place the chip extractor so that its power switch is easily accessible.

### Wire kit

10 metres (33 ft) of wire, rollers and turnbuckles for suspension of chip hose and power cable.  
Ref. no. 9999P000P9999

### Chip chute

Compatible with the Log House Moulder LM410.  
D 100 mm (4").  
Ref. no. 9999P000P9999

### Chip hose

The wood debris should be conveyed in sheet metal pipes. This is cheaper and gives less resistance for the air flow and the wood debris. However, closest to the sawmill and the log moulder you have to use a flexible chip hose. If you are going to suspend the hose on a wire from the ceiling, you should add 2 m (6 ft) to the hose length. Flexi hose, D 100 mm.  
Ref. no. 9999-000-9999

### Chip Extractor

Logosol has a wide range of suitable chip extractors. Consult our customer service to get the right equipment.



## MAINTENANCE

⚠ Risk of serious injury if maintenance is neglected.

The LM410 is easy to maintain since most of the machine structure is protected against rust. All cutter bearings and the motor are maintenance free. Necessary maintenance is set out below.

⚠ Ensure that the power is disconnected before opening the hatch for the cutter or removing any protective covers.

Tip: Compressed air can be very useful for blowing the machine clean each time you open the hatch. Use ear protection and safety goggles.

### When the machine is being used

- Clean the machine from wood debris each time it has been used. Especially ensure that wood debris has not accumulated on the motor or in the cooling fan of the motor. This can interfere with the cooling of the motor and lead to a motor breakdown or, at worst, fire.

### After each working session

- Clean the machine from loose wood debris and dust with a soft brush or compressed air (in that case use ear protection and safety goggles). Also check chip chutes and chip hoses.

- Cleaning and rust protection with Universal Oil 9999-000-5105: Dried sap and resin can be removed with universal oil. Also spray a thin layer on the cutter head, the knives and the ball bearings of the wheel suspension as a rust protective measure. Avoid getting large amounts of oil on the belt transmission. When changing knives or remounting knives, the knife slot in the cutter head, the knife gibs and the knives should be cleaned very thoroughly. The slightest trace of wood debris on the contact surfaces of the knife can lead to total breakdown and risk of personal injury as the knife breaks.

- Lubrication points for Silicone, Ref. no: 9999-000-5110: The power inlet on the machine and the plug on the power cable. Lubricate all plastic parts and cables when cleaning the machine.

- Lubrication points for Super Flo, Ref. no:9999-000-5115: The transmission chain, the sprockets and the trapezoidal threaded bars. Super Flo is a dry, non-adhesive lubricant. Do not use ordinary oil on

the trapezoidal threaded bars, since it makes wood debris and dust stick to them.

- Check the safety switch on the hatch:  
Disconnect the power and make sure that the safety switch on the cutter-head hatch works. The switch is to be clean and its button easy to move. (It should not be possible to start the machine when the hatch is open.)

### If the machine is not being used during a long period of time

- Disconnect the power.

- Clean the entire machine extra carefully, and perform the same maintenance as after each working session. Do not forget the lubrication points.

- Remove knives and knife gibs/chip breakers. Keep these well lubricated and at room temperature.

- Place the machine so that it is not in contact with the ground. Cover the machine with a tarpaulin.

### Before starting the machine after a longer period of storage

Condensation can accumulate in the motor and in the control panel if the machine has been stored in a cold room for a longer period of time. The motor has a drain plug on its underside. Open the plug and empty out any water. Open the control panel and dry up accumulated water.



*The chain transmission should run easily! In the photo you can also see the chain tensioner.*

## TROUBLESHOOTING

Problem	Possible Cause	Remedy
The motor cannot be started.	<ol style="list-style-type: none"> <li>1. The hatch is not entirely closed.</li> <li>2. The hold-to-run buttons are not pressed down.</li> <li>3. No power is supplied to the machine.</li> <li>4. The motor is overheated.</li> <li>5. Electrical system fault.</li> <li>6. Wood debris has accumulated in the safety switch in the cover.</li> </ol>	<ol style="list-style-type: none"> <li>1. Tighten the locking bolt on the hatch. You can hear a soft click when the safety switch is activated.</li> <li>2. Press both the start buttons simultaneously.</li> <li>3. Check the residual circuit breaker and the fuses in the building. Also check the connecting cable.</li> <li>4. Wait until the overheating protection of the motor automatically resets</li> <li>5. The electrical system may only be opened by a qualified electrician: First of all, check the safety hold circuit. This circuit includes, among other things, the hold-to-run buttons, the safety switch and the overheating protection in the connection block on the motor.</li> <li>6. The electrical system may only be opened by a qualified electrician: Open and clean the safety switch from wood debris.</li> </ol>
The cutter head rotates a long time after the machine has been shut off (it should stop within 10 seconds).	<ol style="list-style-type: none"> <li>1. The belt is too loosely tensioned.</li> <li>2. The belt is worn out.</li> </ol>	<ol style="list-style-type: none"> <li>1. Tighten the belt.</li> <li>2. Replace the belt.</li> </ol>
The machine runs for a while but then stops.	<ol style="list-style-type: none"> <li>1. The motor becomes overheated.</li> </ol>	<ol style="list-style-type: none"> <li>1. See the point <i>The motor gets overheated</i> below.</li> </ol>

Problem	Possible Cause	Remedy
The motor becomes overheated.	<ol style="list-style-type: none"> <li>1. Wood debris has accumulated on the motor and around its cooling fan.</li> <li>2. Dull knives.</li> <li>3. Too low voltage in the power supply.</li> <li>4. Loose or bad connection in the power supply to the machine or in the electrical system of the machine.</li> <li>5. The cutter takes off too much wood.</li> <li>6. The feeding speed is too high.</li> </ol>	<ol style="list-style-type: none"> <li>1. Clean. If the motor is kept clean it will be cooled more efficiently.</li> <li>2. Sharpen or replace the knives.</li> <li>3. The electrical system may only be opened by a qualified electrician: Check that you have the correct voltage on all phases and that the power cable is correctly dimensioned.</li> <li>4. The electrical system may only be opened by a qualified electrician: First of all, check that the power cable has the correct current and voltage during operation. Also check that all wires are correctly connected in the electrical system and in the motor of the machine.</li> <li>5. If the workpiece is too wide, of a hard sort of wood or of varying oversizes: Machine the log in several steps and just take off a little bit at a time.</li> <li>6. Lower the feeding speed.</li> </ol>
Vibration or rumble in the cutter.	<ol style="list-style-type: none"> <li>1. The moulding knives are incorrectly installed.</li> <li>2. The moulding knives or the planing knives are incorrectly sharpened.</li> <li>3. Defect bearing.</li> <li>4. Defect belt transmission.</li> </ol>	<ol style="list-style-type: none"> <li>1. Clean and install the knives and the knife gibs/chip breakers correctly. Identical knives should be installed in the same lateral position on opposite sides of the cutter.</li> <li>2. Sharpen the knives in pairs so that they are identical on the opposite sides of the cutter.</li> <li>3. Clean the bearing housing and replace the ball bearing.</li> <li>4. Clean the belt pulleys and replace the Poly V belt.</li> </ol>
The machine table is difficult to adjust in height.	<ol style="list-style-type: none"> <li>1. The trapezoidal threaded bars, on which the table is suspended, are dirty and not lubricated.</li> <li>2. Faulty chain transmission.</li> <li>3. The machine has been subject to impact which has spoiled the setting of the table.</li> </ol>	<ol style="list-style-type: none"> <li>1. Clean and lubricate the trapezoidal threaded bars with Super-flo.</li> <li>2. Make sure that the chain runs correctly on the sprockets. Clean and lubricate the chain.</li> <li>3. Adjust the table so that it lies flat on all nuts.</li> </ol>

## **ELECTRICAL SYSTEM**

The LM410 is available in two electric models: 230 V 3-phase 50 Hz and 400 V 3-phase 50 Hz.

The power cable to the log house moulder must be at least 2.5 mm<sup>2</sup>/wire (1/8") and be max. 25 m (82 ft) long. If you have to use a longer cable, it must be 4 mm<sup>2</sup>/wire on the length that is more than 25 m.

If the log house moulder is stored in a cold room, fluctuations in temperature will cause condensation to accumulate in the motor and the junction box. Check regularly that there is no water in the junction box behind the control panel or in the enclosure of the three-phase motor. The motor has a drain plug on its underside.

The motor is started by a contactor. The power that runs the electromagnet in the contactor, runs through the two hold-to-run buttons and the safety switch on the cutter-head hatch. All these three have to work and be activated for the motor to start.

Lubricate the industrial power inlet on the LM410 and the plug on the cable with silicone spray.

**⚠** Lethal voltage. A faulty connection can lead to death or serious injury.

**ⓘ** Note that only qualified electricians are authorized to open/access the electrical equipment.

**ⓘ** Ensure that the power is disconnected before opening the electrical system.

### **CIRCUIT DIAGRAM 400 V 3-PHASE**

**ⓘ** You can find the current circuit diagram for your log house moulder inside the junction box of your machine.

### **CIRCUIT DIAGRAM 230 V 3-PHASE**

**ⓘ** You can find the current circuit diagram for your log house moulder inside the junction box of your machine.





Fiskaregatan 2, 871 33 Härnösand, SWEDEN  
+46 611 182 85 | [info@logosol.com](mailto:info@logosol.com) | [www.logosol.com](http://www.logosol.com)